

**45L
ATTACHED LID
CONTAINER
ALC-45LE
DATASHEET**

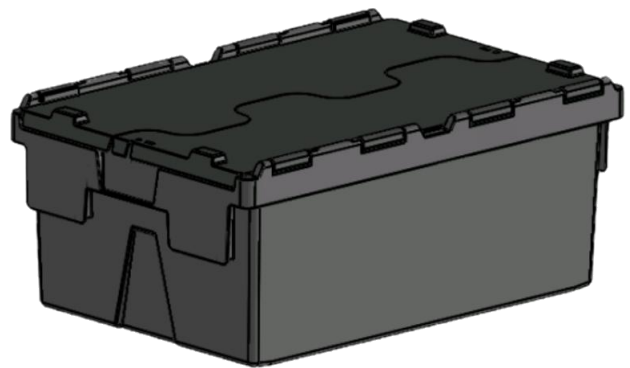

Casting Support Systems Ltd
Systems House, 1 Claylands Way,
Paignton, TQ4 7TY, UK.

t. +44 (0)1803 226 961
e. sales@versatote.com
w. www.versatote.com



Datasheet: ALC-45LE

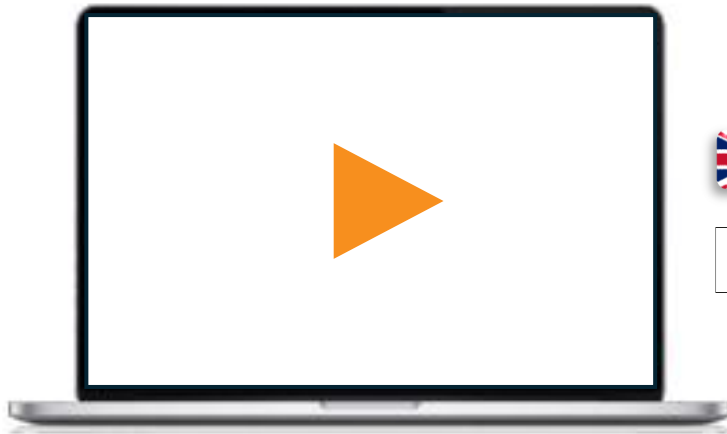

Designed and manufactured in the UK



Manufactured to ISO9001 quality standards

Take the 360 tour press the play button

Design Features

- Interlocking lid with tamper proof seal holes locking into both base and lid.
- Lid designed to interlock additional totes when stacked, lowering movement risk in transit
- Traditional Kaiman design, giving additional locking when nested together when empty.
- Additional indentations can be added, to create an easy peel surface to remove transit labels.

Additional Options

- Available in 3 material options virgin plastic, 70:30 virgin : recycled plastic (other % options are available on request) and Repro -100% recycled plastic.
- Available in a variety of colours both base and lid(please be aware colours restrictions are linked to material type)
- Laminated digital printing, for either logos, images or writing . Maximum print size (85mm Height x 250mm width)
- Security tamper proof seals available, again available in any colour or quantity.
- Labels and barcodes can be added either being provided by us or the customer.
- Option to reprocess your old plastic boxes, giving you a price per kilo (please contact for availability) We are not responsible for collection or delivery for this service.

Casting Support Systems Ltd
Systems House, 1 Claylands Way,
Paignton, TQ4 7TY, UK.

t. +44 (0)1803 226 961
e. sales@versatote.com
w. www.versatote.com



Datasheet: ALC-45LE

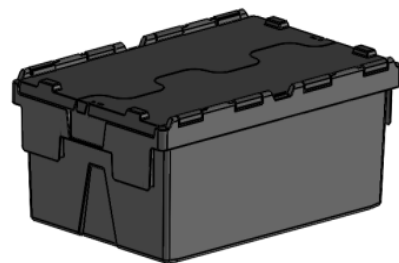
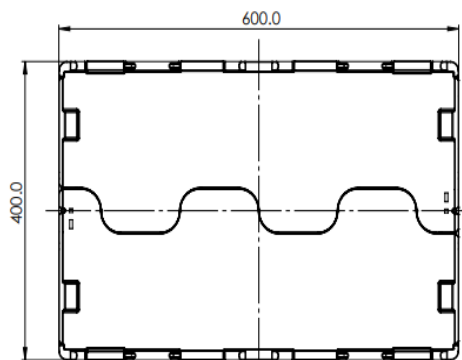

45 LE ALC
General wall thickness: 2.75mm
Property of CSS Group

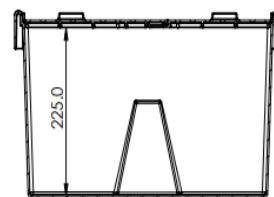
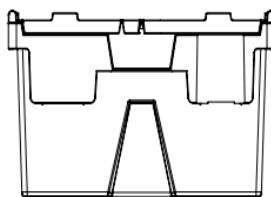
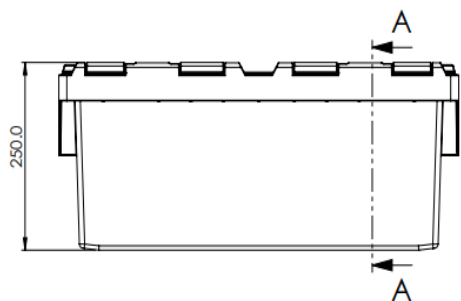

SECTION A-A

Technical data

Product reference:	ALC 45L-LE
External dimensions (mm):	600L x 400W x 250H
Wall thickness (mm)	2.75
Usable internal height (mm):	225
Weight Kgs:	2.94
Quantity per pallet:	75
Pallets per truck load (ALC empty):	22 (Full (26))

Casting Support Systems Ltd
Systems House, 1 Claylands Way,
Paignton, TQ4 7TY, UK.

t. +44 (0)1803 226 961
e. sales@versatote.com
w. www.versatote.com



CASTING SUPPORT SYSTEMS LTD

Datasheet: ALC-45LE

Safety Instructions for End User

- Ensure follow HSE [Simple manual handling risk filters – HSE](#).
- Avoid awkward postures, twisting and using excessive force.
- Hand and foot protection should be worn.
- Wash hands after handling ALC, as they can become dirty if not washed over a period of time.

Potential Hazards/ Injuries

- Force (Push and pull)
- Sprains and strains
- Awkward posture
- Slips, trips and falls
- Pinch/crush injuries
- Hygiene control

Pre-Operation Safety Checks

- DO NOT climb into or onto attached lid container
- Test the weight of the attached lid container before moving.
- Avoid overloading attached lid container and do not handle overloaded the attached lid container.
- Do not handle multiple attached lid containers at once.
- CSS recommend operations introduce processes and procedures to assist in health and safety.

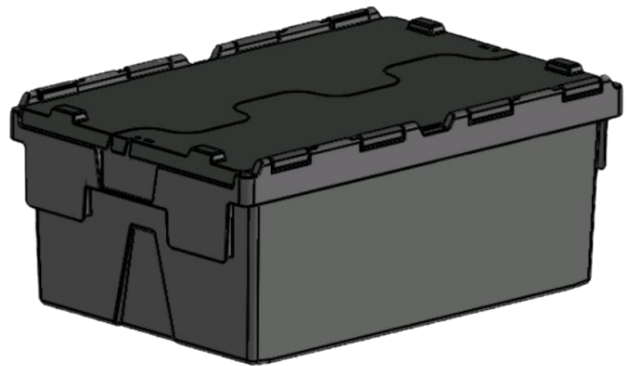

Casting Support Systems Ltd

Systems House, 1 Claylands Way,
Paignton, TQ4 7TY, UK.

t. +44 (0)1803 226 961
e. sales@versatote.com
w. www.versatote.com

